

CertainTeed Ceilings Ecophon® Focus™ D 4x4 Installation Instructions

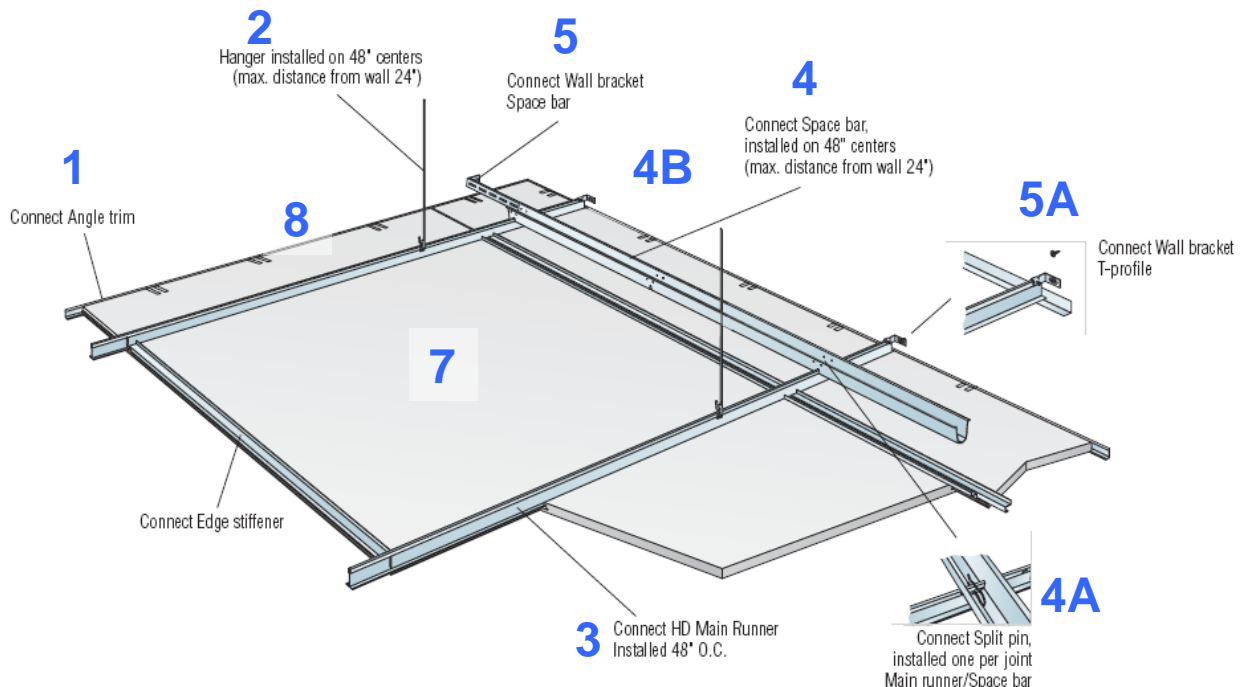

Pre-Installation: Please read *CertainTeed Ceiling's Pre-Installation Instructions* before you begin these installation instructions. Note that the finished surface of Focus D Panels is $\frac{1}{2}$ " below the grid. **Focus D is an extremely precise system and the tolerance is very small. The grid system must be square and level.**

1. Installing Wall Molding

- To install Wall Molding, in this case Connect Angle Trim, choose a height at least three inches below joists, existing ceilings, ducts, pipes, or wiring, to ensure clearance and maneuverability required to install the panels.
- Mark the desired height for the finished surface of the ceiling on all four walls.
- Attach Wall Molding using proper fasteners.

2. Install Hangers

- Mark lines for each of the main runners (4' on center).
- Pull a string line along the path that the first main runner will take. Attach the line directly below the wall molding.
- Hangers should be placed every 48" along the main runners, at a max of 24" from the walls.

3. Install the first 3 Main Runners

- Install the first section of main runner, with cut edge sitting on the wall molding.
- Attach the main runner to wire.
- Repeat for the next two sections of main runner. (Be sure that the cross tee slots in all three main runners line up, or the Connect Space Bar will not install).

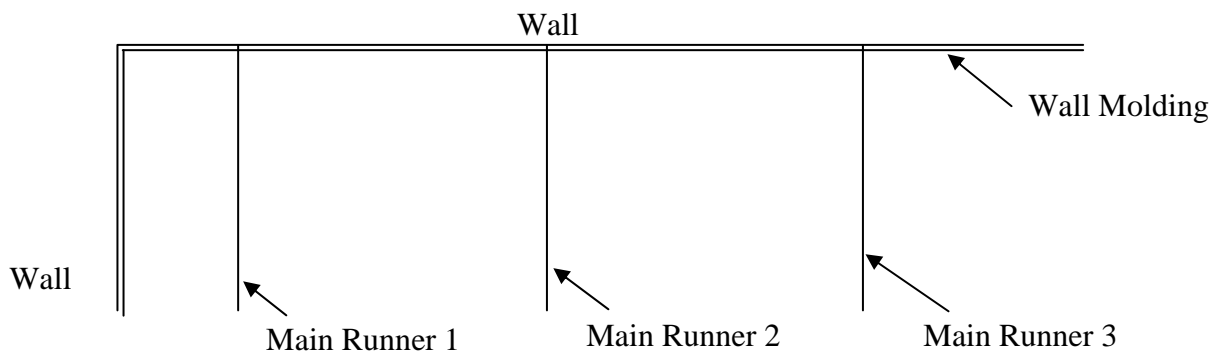

4. Install Connect Space Bar (Space Bars take the place of Cross Tees)

- Establish the location of the first Space Bar (Max distance of 24" from both walls. Space Bar should not be mounted above the intended panel joint.)
- Place the Space bar on top of the three main runners, and insert split pin through the cross tee slot (see 4A).

4A. Each main runner should get pinned as illustrated below

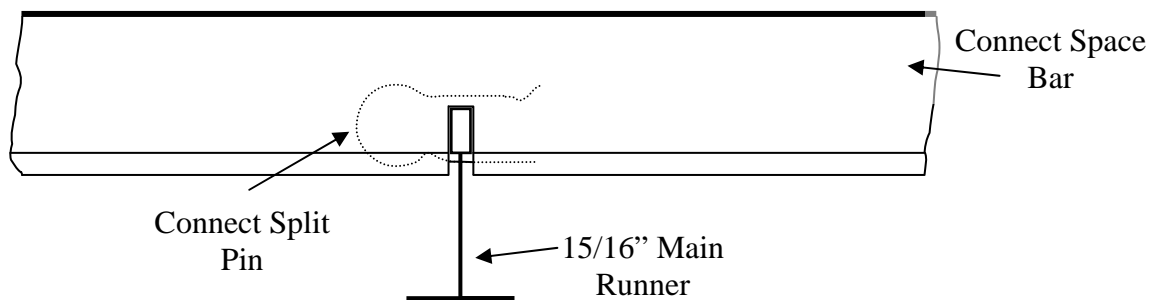

4B. Square the Grid System

- Check to see if the system is square by measuring diagonally across the opening between the main runners. The measurements should be equal if the system is square.

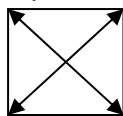

5. Using screws, attach the Connect Wall Bracket Space Bar to the Connect Space Bar, and then attach the Connect Wall Bracket Space Bar to the Wall.

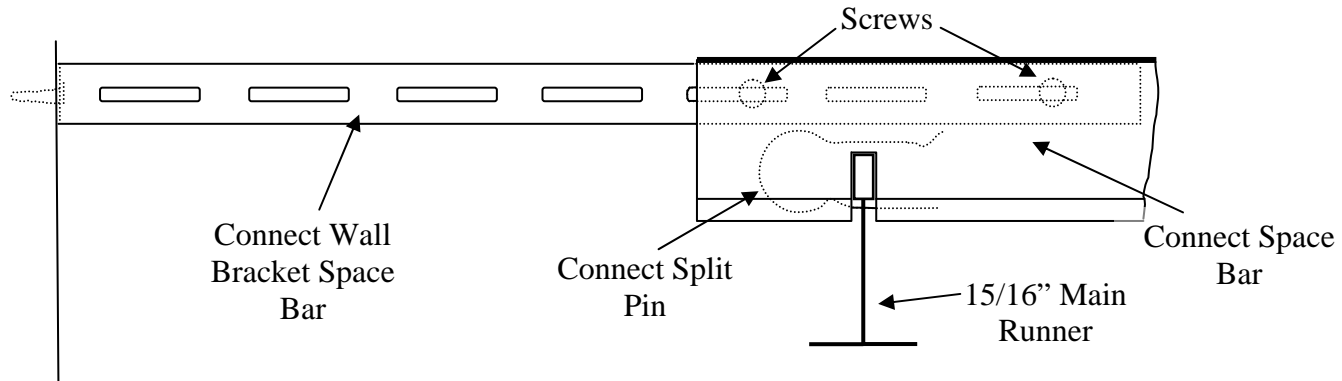

- 5A. Using Screws, attach the Connect Wall Bracket T-profile to the bulb of the Main Runner, then to the wall.

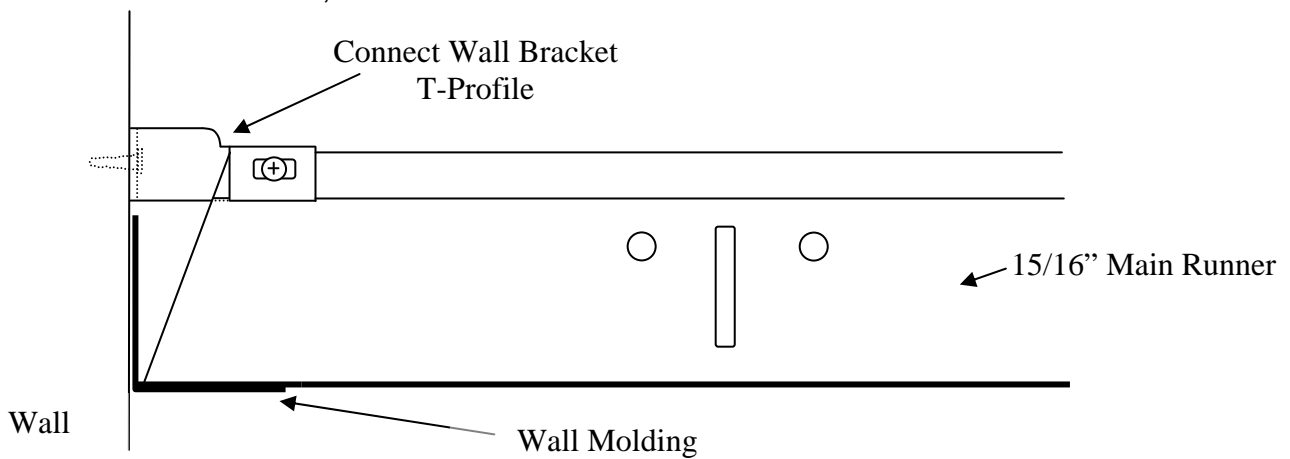

6. Repeat Steps 3-5 until the entire suspension system is installed.
Note: Space bars are 8'2", and are installed not more than 24" from any wall. They are installed 48" on center in the field, and should not be installed directly above a panel joint. Space bars in parallel runs should be staggered 6-inches to the next cross tee slot, so they can be properly pinned. (Illustrated below)

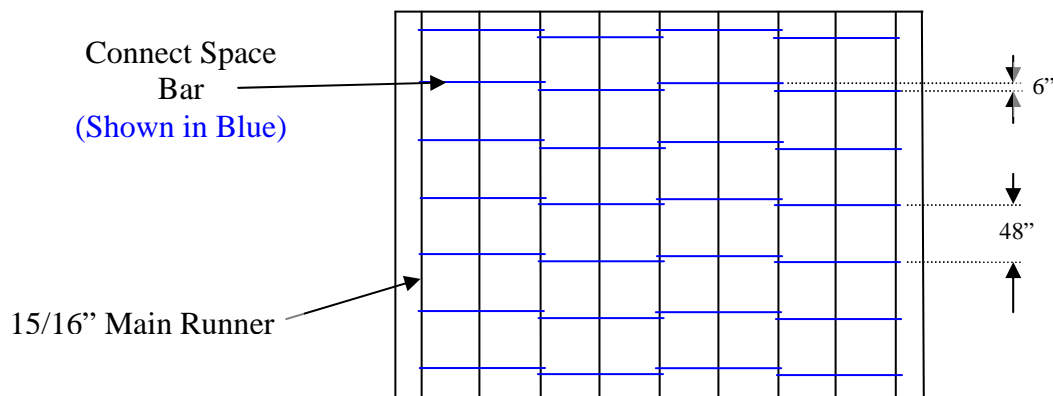

7. Install Panels (each panel requires 2 installers)

Before you begin installing the panels, you must understand that Focus D panels have 2 supporting sides and 2 non-supporting sides. As illustrated below:

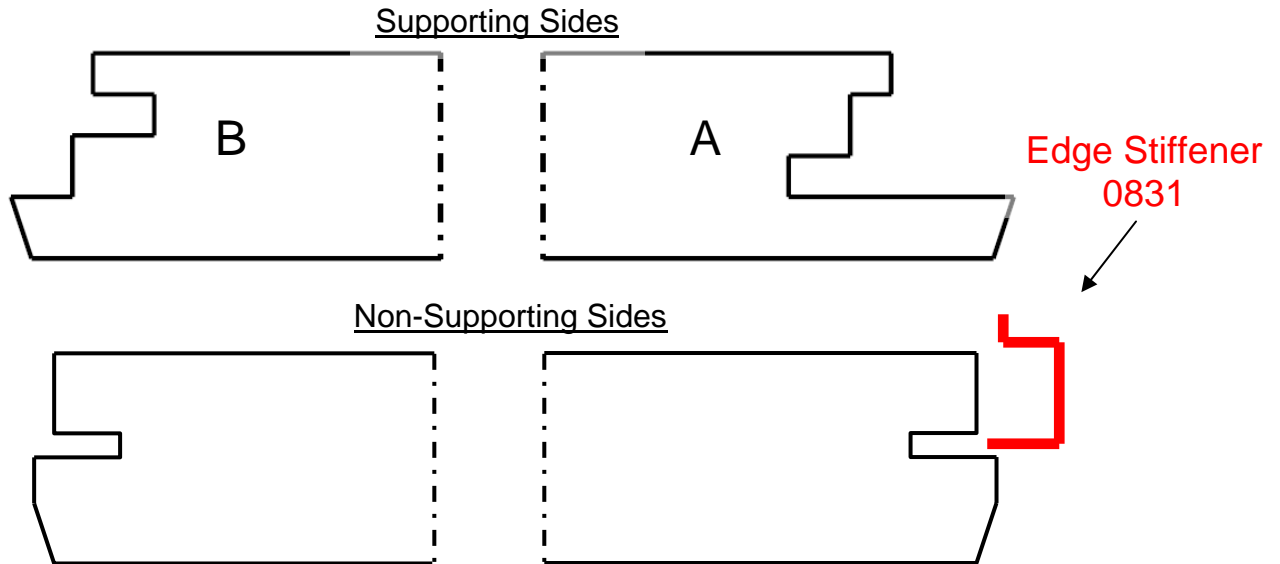

*Please note that the 2 non-supporting sides of the panels **must** receive an edge stiffener.*

- Install temporary string lines along the path where the panel joints will meet. (since there are no cross tees as a reference)
- **Put on white cotton gloves, so that the dirt and oil from your hands, does not get on the panels. (If gloves become soiled, replace them immediately.)**
- **Before installing** each panel, insert an Edge Stiffener in **each** of the non-supporting sides on the panel by gently applying pressure.

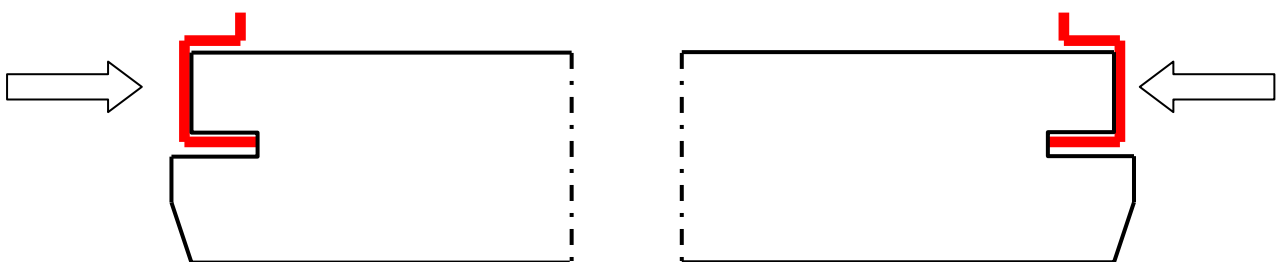

- Start installing panels in the middle of the field.

- To install Focus D Panels, Follow the Directions Below:

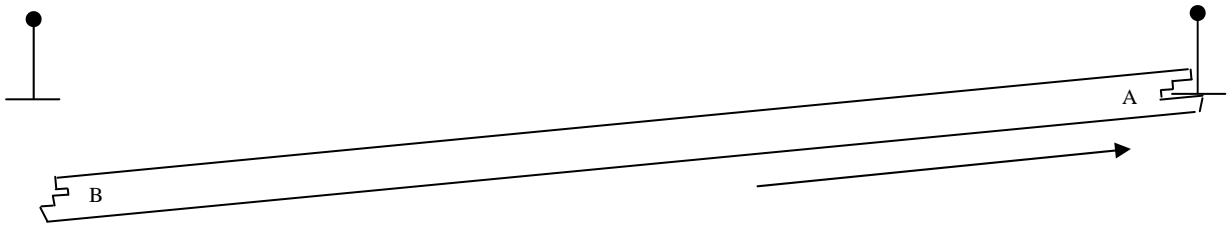

Step 1: Place your leading edge (A) into the grid as shown, making sure that the wider (deeper) groove is pushed as far as it can go into the flange. (This will give you the room to ensure that the trail edge (B) clears the grid on the opposing side).

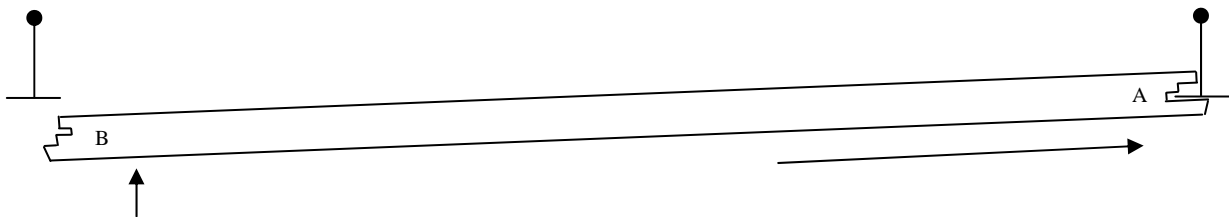

Step 2: Keeping pressure toward edge (A), start to push edge (B) up toward the Plenum.

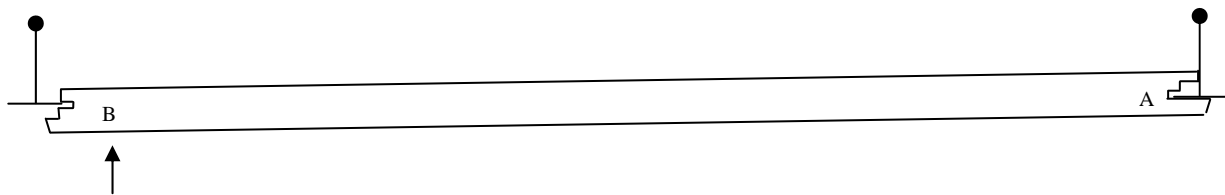

Step 3: Push edge (B) up and begin to engage the flange on the grid.

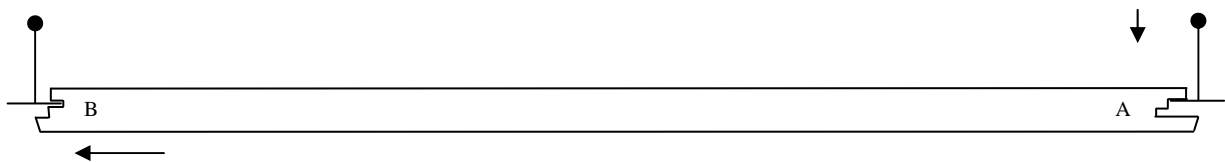

Step 4: Slide panel toward edge (B) until the top ledge of edge (A) seats itself on the grid flange.

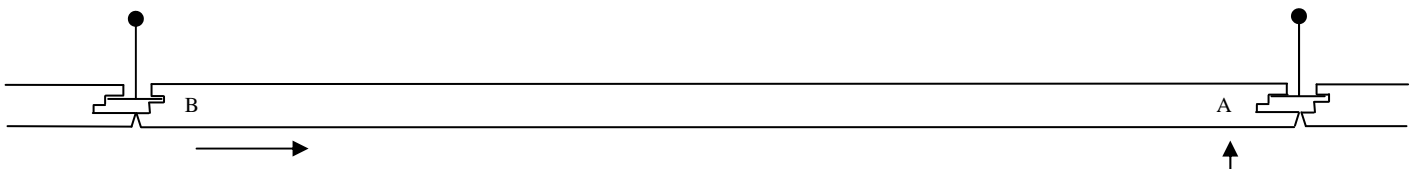

Step 5: To remove the panel, lift up gently on edge (A) and perform the process in reverse

(Step 8 continued on next page)

8. Install Border Panels

To better understand installing border panels/edge treatment, consult the illustration below. (Ex. Focus D 4x4 Install top view)

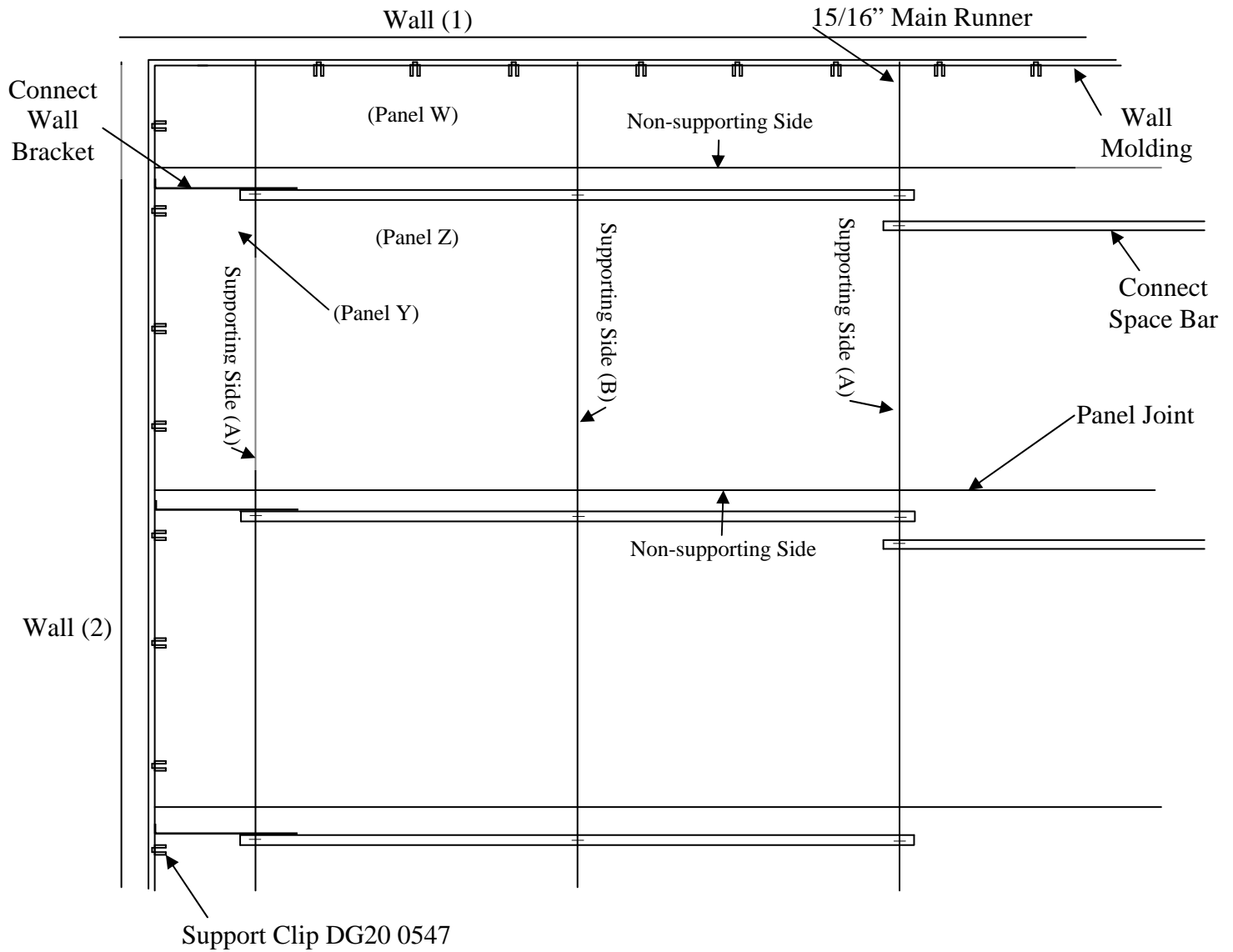

To install the border panels along Wall 1, follow these instructions:

- Since you are cutting off one of the non-supporting sides, you will have to cut through the panel completely, and then remove a rabbet from the back side of the panel. Below is an illustration of the edge detail along Wall 1.

Wall 1 with Wall Molding

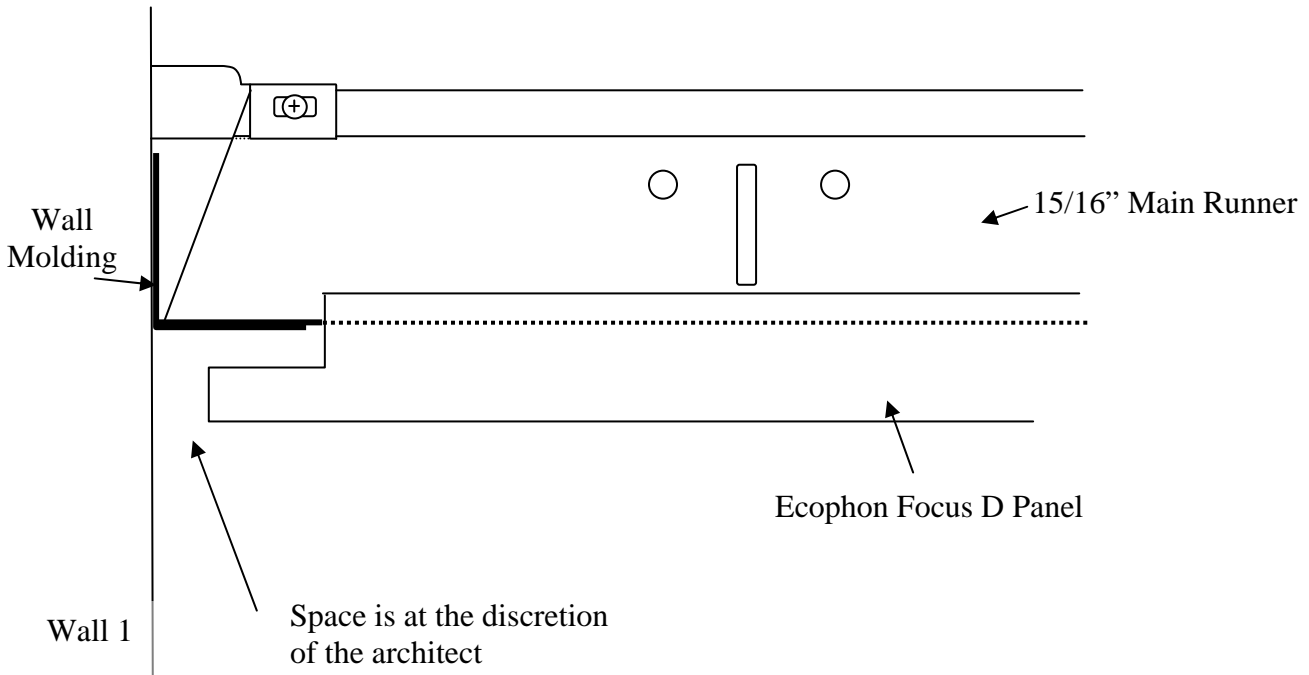

*The illustration below shows a side view of the supported side for panel W, or the 4' side of Focus D panels. Please note that the following **directions can be used** for cutting the **non-supporting sides (4')**.*

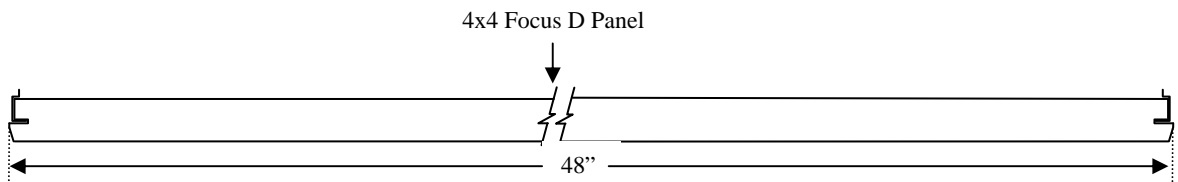

This System is designed so that 5/16" of the wall molding is visible around the border of the room; however, this distance is at the Architect's discretion. If the Architect does not specify the distance, the following directions will result in a 5/16" gap around the border.

- Cut border panels by measuring each one individually. Measure from the wall molding (X) to the outside edge of the next tile in the field, in this case 18". Add 1/2" to that number for the gap around the border, which is 18 1/2". Transfer the measurements to the panel you plan to cut. (For more accurate edges, measure at least twice at each end of the tile, so your cut matches the contour of the wall. (Panel W above)

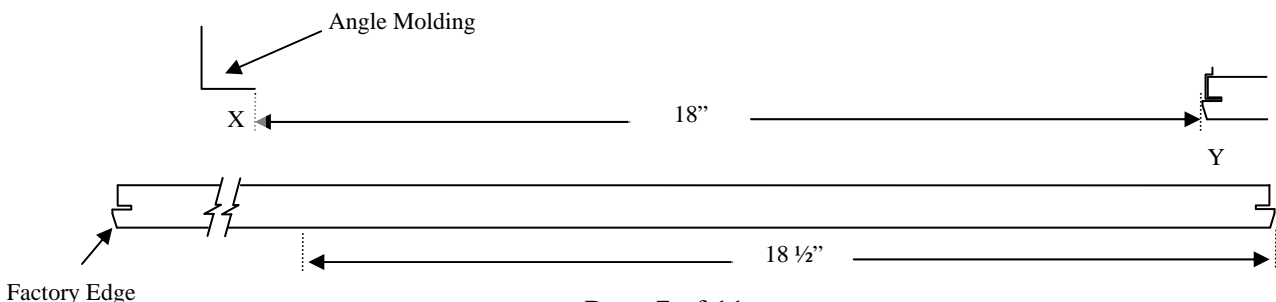

- Using a straightedge, cut the panel.

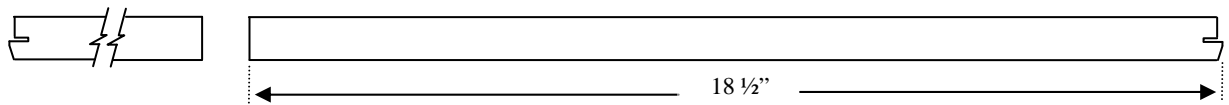

- After you make the straight cut, the panel must be back-cut to partially conceal the Wall Molding. A 9/16" x 9/16" rabbet must be back-cut into the panel. The rabbet can be cut with an Ecophon Cutting Tool (leave shim in), or with a regular razor knife. (Illustrated below).

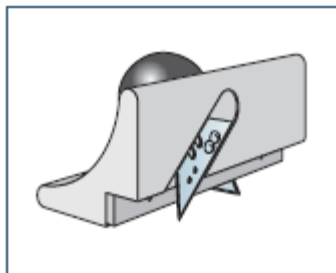

Cutting tool DG 0991

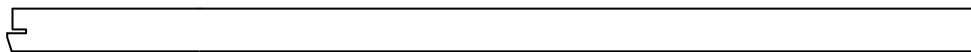
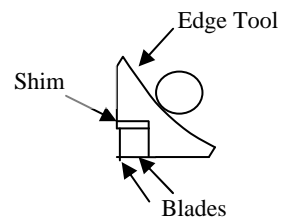

Using the Edge Tool, follow the arrows on the face of the tool, and place the tool on the unfinished back of the panel. Keeping steady pressure on the tool, slide it along the panel and cut out the rabbet. Remove the cut piece and discard.

Edge Cutting: Non-Supporting Edge

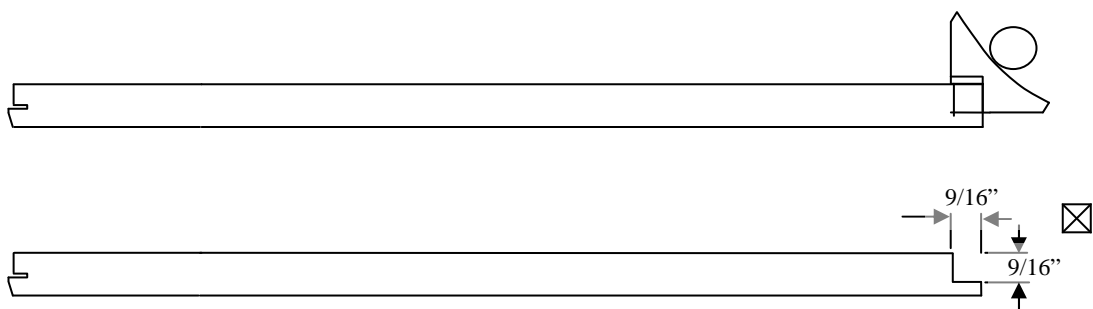

Note: You can cut the rabbet with a razor knife and straightedge.

- Insert an Edge Stiffener in the factory non-supporting side of the cut panel by gently applying pressure. Along cut non-supporting edges you only need clips if the cut edge is longer than 2'. In this example, the cut edge is 48" long, so it will need to be clipped every 12-18 inches. The clips are pushed into the panels with the single pointed flange down, and the 2 rectangular flanges on top of the panel.

- It is left to the Architect to decide if the cut edge should be sealed with Ecophon Edge Sealant or left unpainted.

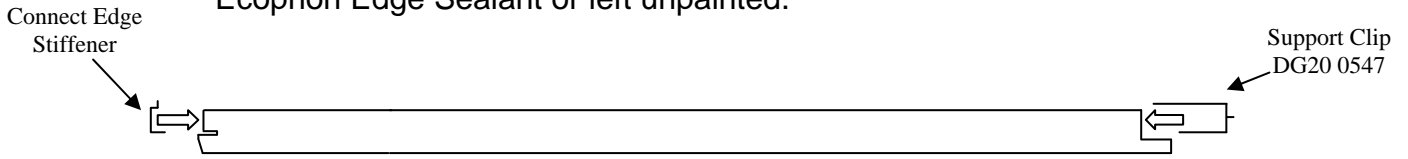

- To install Panel W, you must first remove Panel Z. Since the Clips on Panel W will rest on top of the wall molding, it is necessary to remove Panel Z. Once Panel Z is removed, install Panel W with the cut/clipped side toward the wall and several inches from the wall. Once Panel W is in the grid, gently slide it into place (toward the wall). Install Panel Z.

To install the border panels along Wall 2, follow these instructions:

- Along **Wall 2**, you will have to cut off one of the long sides (supporting sides) of the panel. You should always cut **Edge B** off of the panels because **Edge A** has the deeper Z-groove which must be installed first. (Panel Y above)

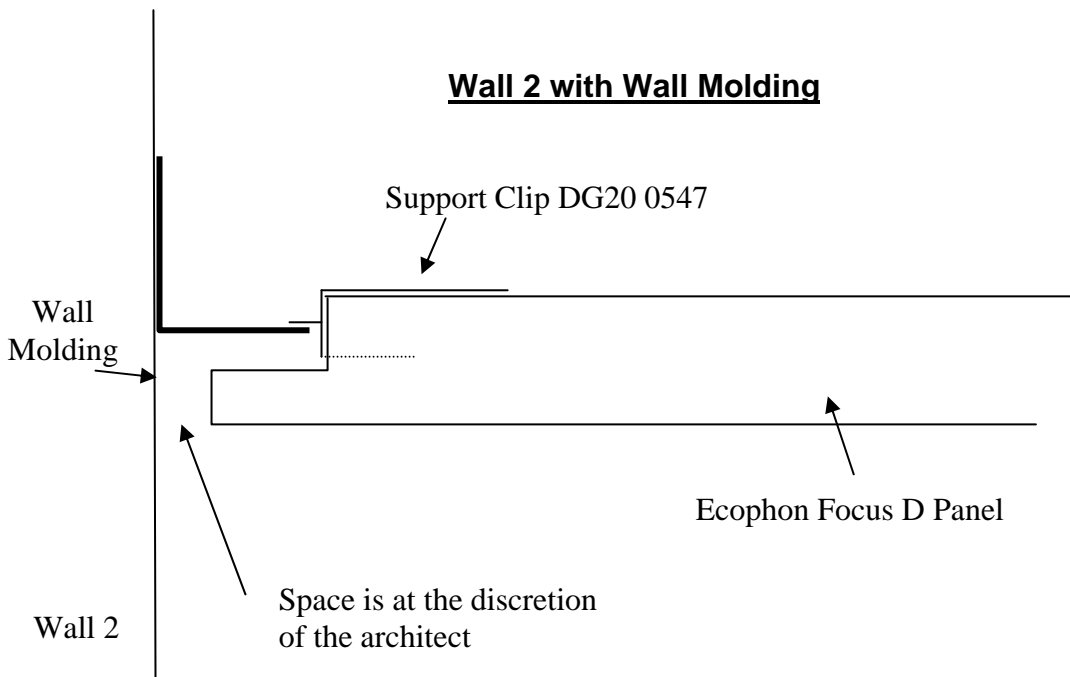

*The illustration below shows a side view of the non-supported side for panel Y, or the 4' side of Focus D panels. Please note that the following **directions can be used** for cutting the **supporting sides** (4').*

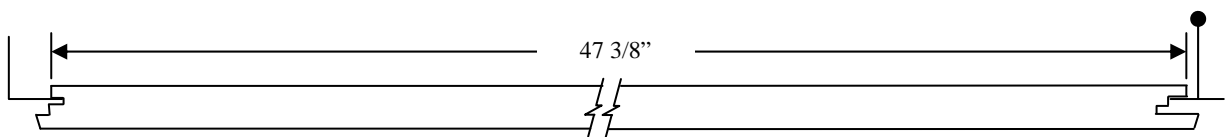

This System is designed so that 5/16" of the wall molding is visible around the border of the room; however, this distance is at the Architect's discretion. If the Architect does not specify the distance, the following directions will result in a 5/16" gap around the border.

- Cut border panels by measuring each one individually. Measure from the wall (X) to the outside edge of the grid (Y), in this case 17 1/4". Transfer the measurements to the panel you plan to cut, making sure that you are starting your measurement from the (A) edge of the panel, so that you are cutting off the (B) edge. If the distance from (X) to (Y) is more than 24", the edge stiffeners must be cut and inserted into the cut panel to prevent sagging. (For more accurate edges, measure at least twice at each end of the panel, so your cut follows the contour of the wall).

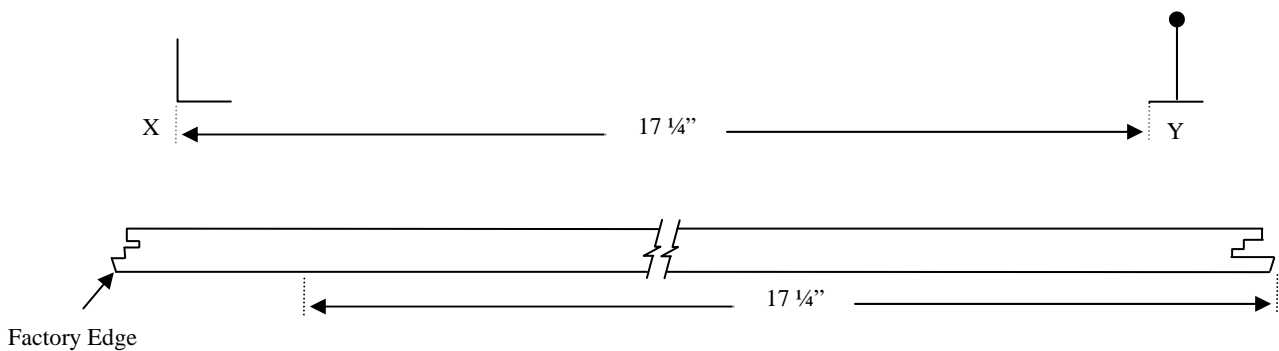

- Using a straightedge, cut the panel.

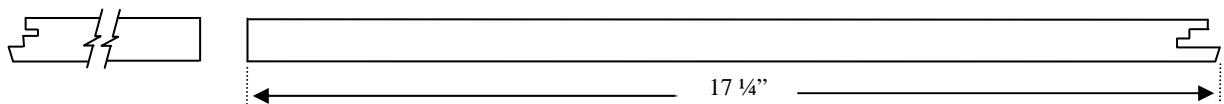

- After you make the straight cut, the panel must be back cut to partially conceal the Wall Molding. A 9/16" x 9/16" rabbet must be back cut into the panel. The rabbet can be cut with an Ecophon Cutting Tool (leave shim in), or with a regular razor knife. (Illustrated below).

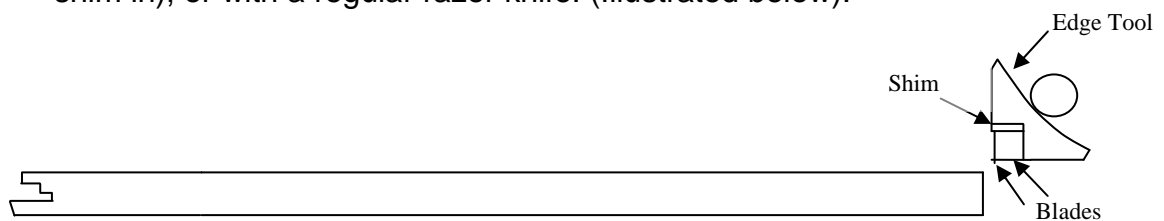

Using the Edge Tool, follow the arrows on the face of the tool, and place the tool on the unfinished back of the panel. Keeping steady pressure on the tool, slide it along the panel and cut out the rabbet. Remove the cut piece and discard.

Edge Cutting: Supporting Edge

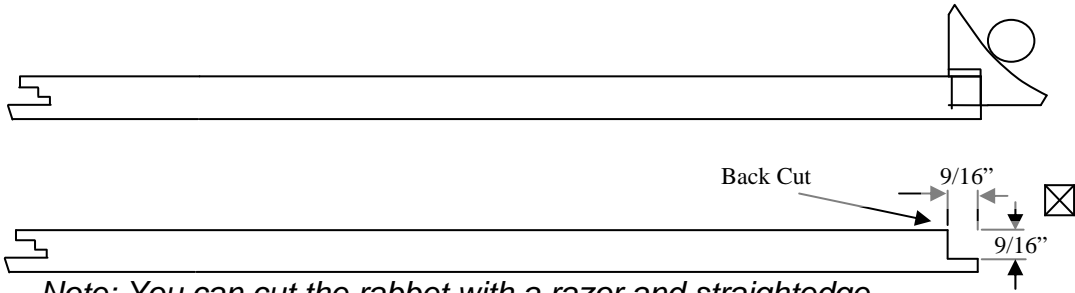

Note: You can cut the rabbet with a razor and straightedge.

- Since one of the supporting sides of the panel has been removed, support clips must be placed every 12"-18" along the cut edge of the panel as illustrated below. The clips are pushed into the panels with the single pointed flange down, and the 2 rectangular flanges on top of the panel.
- It is left to the Architect to decide if the cut edge should be sealed with Ecophon Edge Sealant or left unpainted.
- Panels with clips install the same way as normal panels, Edge A in first.

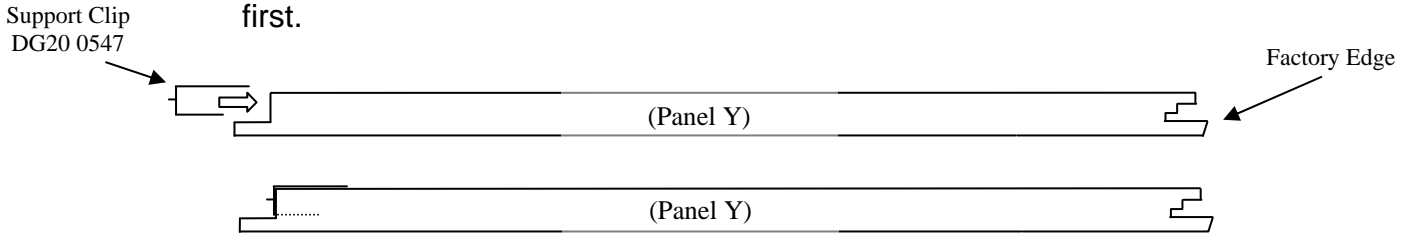

- To install Panel Y, slide the factory edge into the grid facing the field.

